



**LAM-É
ST-PIERRE**



UNIVERSAL PLATE LIFTING CLAMP

FEATURES



- Can be used for lifting and transfer of steel plates
- Lever insures pre-tensioning and release of grip jaws
- 180° turning range for material transfer, turning or moving
- For use with materials having surface hardness of less 37 Rockwell (345 Brinell)
- Individually serialized and tested to 2 x WLL
- A factory certification of proof load is included with every clamp
- Available in different capacities
- Conformity with ASME B30.20
- Replacement parts are available

PRODUCT NO.	STOCK NO.	DESCRIPTION	WLL (M.T.)	WEIGHT (LBS.)
IPU10-0.5AMH-7A	PCUA005	UNIVERSAL LIFTING CLAMP. 1/2MT. EYE 180° OPENING .0-15MM	1/2	4.5
IPU10-1.0AMH-7A	PCUA010	UNIVERSAL LIFTING CLAMP. 1MT. EYE 180° OPENING .0-20MM	1	9.9
IPU10-2.0AMH-7A	PCUA020	UNIVERSAL LIFTING CLAMP. 2MT. EYE 180° OPENING .0-25MM	2	16.1
IPU10-3.0AMH-7A	PCUA030	UNIVERSAL LIFTING CLAMP. 3MT. EYE 180° OPENING .0-30MM	3	33
IPU10-5.0AMH-7A	PCUA050	UNIVERSAL LIFTING CLAMP. 5MT. EYE 180° OPENING .0-50MM	5	47.50

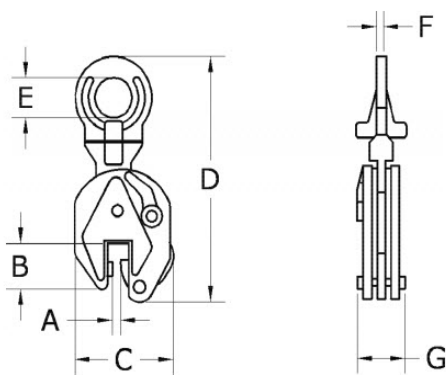

STOCK NO.	WLL (M.T.)	DIMENSIONS (IN.)						
		A	B	C	D	E	F	G
PCUA005	1/2	0-5/8	1.7	4.2	8.5	1.2	0.4	2.0
PCUA010	1	0-3/4	2.5	5.7	11.5	1.9	0.5	2.6
PCUA020	2	0-1	3.1	6.9	14.5	2.7	0.6	3.0
PCUA030	3	0-1 1/8	3.3	8.1	16.9	2.9	0.8	4.0
PCUA050	5	0-2	3.9	9.4	18.95	3.1	0.9	4.3