



Lam-e



St-Pierre



8-204 / SWIVEL HOIST RING



FEATURES

- All YOKE Swivel Hoist Rings meet or exceed all the requirements of ASME B30.26
- Hoist Ring Bails are designed by forged alloy steel, quenched and tempered
- Each forged part and cap screw with Batch code links to Test Certificate sheet
- Hoist Rings are 360° swivel with 180° pivot function
- Bolt are UNC thread, specification is a grade 8 alloy socket head cap screw per ASTM A 574
- Proof Load individually to 2.5 times Working Load Limit and certified
- 100% magnaflux crack detection

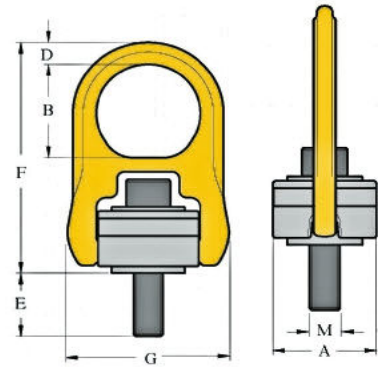

8-204 UNC THREADS

PRODUCT NO.	UPC NO.	WLL (LBS.)	TORQUE IN FT. LBS.	DIMENSIONS (IN.)							WEIGHT (LBS.)
				BOLT SIZE	A	B	D	E	F	G	
HR1255/16182YO-5P	8-204-004	800	7	5/16 - 18 UNC	1.57	1.61	0.35	0.71	4.02	2.56	0.9 0
HR1253/8162YO-5P	8-204-005	1000	12	3/8 - 16 UNC	1.57	1.61	0.35	0.71	4.02	2.56	0.90
HR1251/21325YO-5P	8-204-010	2500	28	1/2 - 13 UNC	2.56	2.32	0.59	0.75	6.26	4.13	3.70
* HR1251/2133YO-5P	8-204-010L	2500	28	1/2 - 13 UNC	2.56	2.32	0.59	1.26	6.26	4.13	3.70
HR1255/81125SWYO-5P	8-204-019	4000	60	5/8 - 11 UNC	2.56	2.32	0.59	0.74	6.26	4.13	4.00
* HR1255/811325YO-5P	8-204-019L	4000	60	5/8 - 11 UNC	2.56	2.32	0.59	1.75	6.26	4.13	4.00
HR1253/410275YO-5P	8-204-021	5000	100	3/4 - 10 UNC	2.56	2.87	0.59	1.24	6.26	4.13	4.00
* HR1253/410325YO-5P	8-204-021L	5000	100	3/4 - 10 UNC	2.56	2.87	0.59	1.73	6.26	4.13	4.20
HR1253/4103YO-5P	8-204-030	7000	100	3/4 - 10 UNC	3.35	2.87	0.59	0.87	6.26	5.28	8.80
* HR1253/410375YO-5P	8-204-030L	7000	100	3/4 - 10 UNC	3.35	2.87	0.87	1.87	8.03	5.28	9.50
HR1257/8935YO-5P	8-204-042	8000	160	7/8 - 9 UNC	3.35	2.87	0.87	1.43	8.03	5.28	9.30
* HR1257/89425YO-5P	8-204-042L	8000	160	7/8 - 9 UNC	3.35	2.87	0.87	2.37	8.03	5.28	9.70
HR1251835YO-5P	8-204-045	10000	230	1 - 8 UNC	3.35	2.87	0.87	1.36	8.03	5.28	9.70
* HR125184.5YO-5P	8-204-045L	10000	230	1 - 8 UNC	3.35	2.87	0.87	2.36	8.03	5.28	10.10
HR12511/4741/2YO-5P	8-204-070	15000	470	1-1/4 - 7 UNC	3.95	3.15	1.00	2.25	8.58	6.30	14.50
HR12511/2665YO-5P	8-204-125	24000	800	1-1/2 - 6 UNC	4.72	4.29	1.38	2.17	12.09	8.66	35.20
HR12524565YO-5P	8-204-135	30000	1100	2 - 4-1/2 UNC	4.72	4.29	1.38	3.01	12.09	8.66	35.20

Safety Factor 5:1

* Long Bolts are designed for soft metal work piece.



Lam-e



Montréal
Québec
Chicoutimi

T 514 354-4219 / 1 800 361-4019
T 418 652-9759 / 1 800 652-9759
T 418 696-9759 / 1 866 696-9759

www.lamestierre.com